

GIULIA BALDASSARI
 MASTER DEGREE: PSSD
 -
 GENERATIVE DESIGN
 POLITECNICO DI MILANO
 A.Y. 2013/2014

MOTTO:
 WHEN THE GAME BECOME TOUGH,
 TOUGH PEOPLE START TO PLAY



CONSTRUCTION OF OWN IDENTITY

FIRST PHASE

TRANS-
 FORMING
 RULES

ATTRIBUTES

INTUITIVE

EMOTIONAL

RIGOROUS

/1
 HOW TO
 SCALE

DOUBLE
 SIZES IN BOTH
 DIMENSIONS

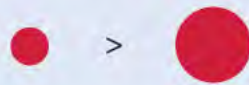

ENLARGE
 ONLY ONE
 DIMENSION



ENLARGE
 ESPONENTIALLY
 (^2, ^3, ...)



/2
 HOW TO
 ROTATE

CLOCK
 WISE



ROTATE
 WITH THE PACE
 OF A SPIRAL

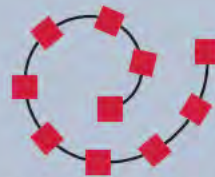

ROTATE BY 45
 DEGREES



/3
 HOW TO
 ORGANISE

FROM THE
 BIGGER AREA,
 FROM LEFT



OBJECTS ARE
 CENETERED
 TO ARTWORK



OBJECTS ARE
 ALLIGNED
 EACH OTHER



/4
 HOW TO
 OVERLAY

DECREASING
 OPACITIES
 (20% BY 20%)



RANDOM
 DECREASING
 OPACITIES



COVER THE
 UNDERNEATHED
 OBJECT



FIRST PROJECT

SECOND PHASE

THEME: BARILLA MANIFEST

CATALYST: CALCIO RETRO
BY YELLOW MELLOW

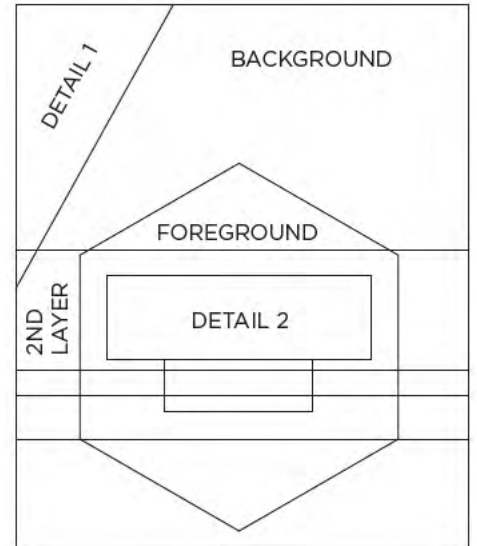

PARADIGM:

ELEMENTS CONNECTED
THROUGH ATTRIBUTES

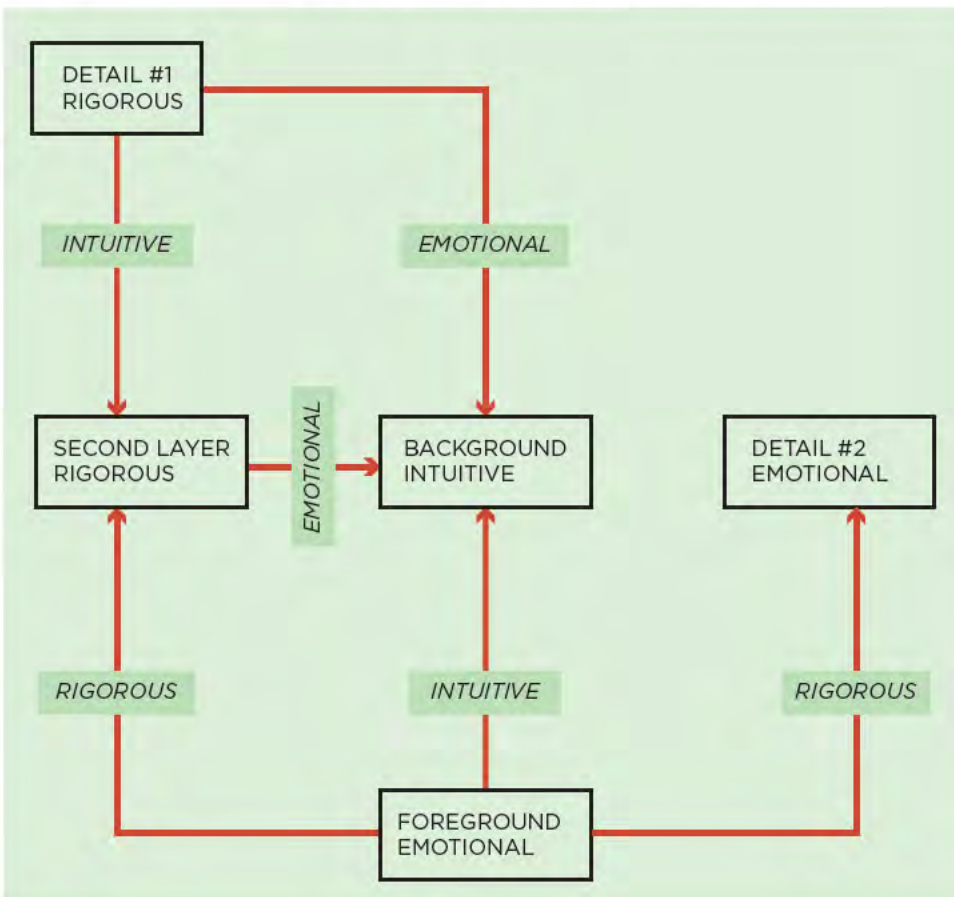

PICTURE

TO
TRANSFORM



FIRST PROJECT

SECOND PHASE

SENARIO #1

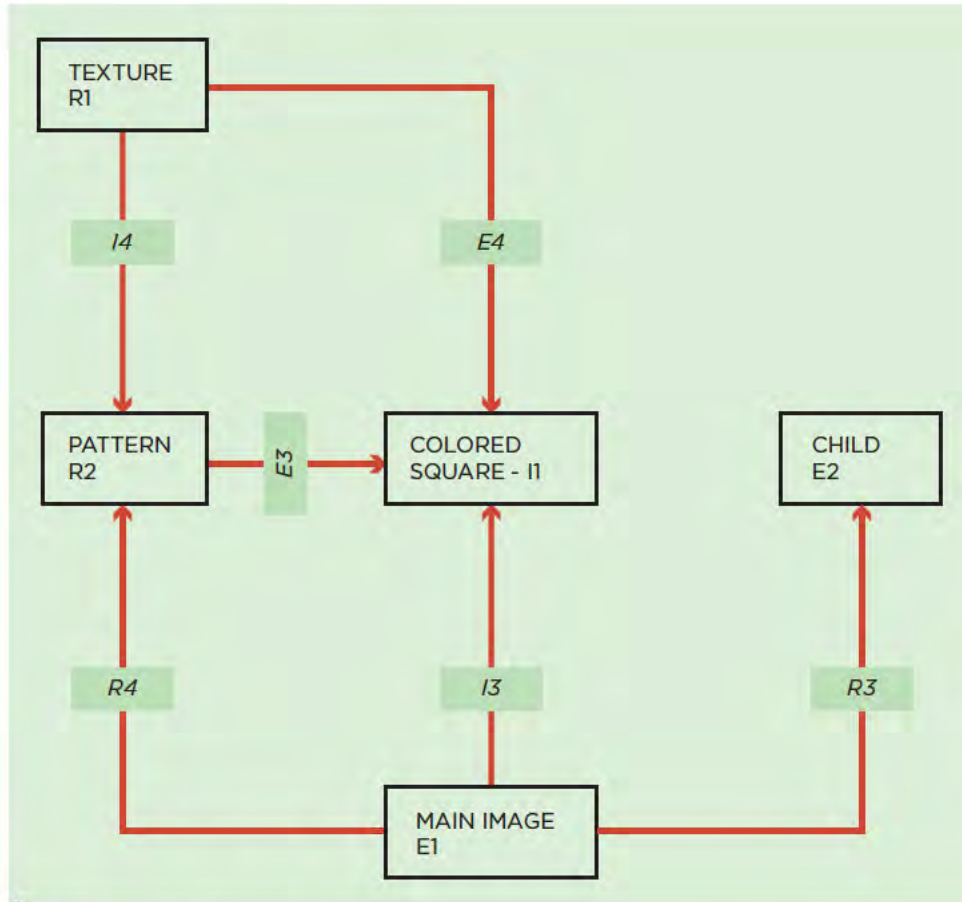

SQUARE



TEXT

BARILLA
PARMA

MAIN IMAGE



SENARIO #2

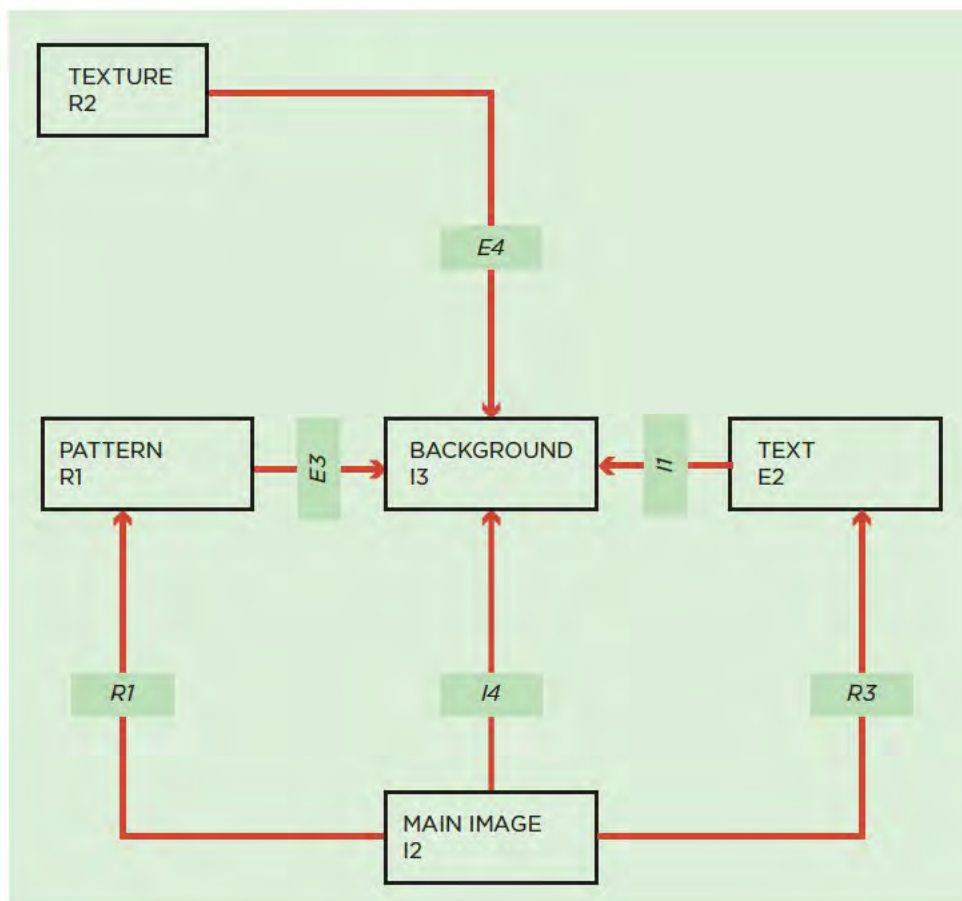

CHILD



TEXTURE



PATTERN



FIRST PROJECT
SECOND PHASE
-
OUTPUT #1



-
OUTPUT #2



SECOND PROJECT

SECOND PHASE

-
THEME: CHILDREN BOOK COVER

-
CATALYST: LED ZEPPELIN'S ALBUM
CELEBRITY DAY

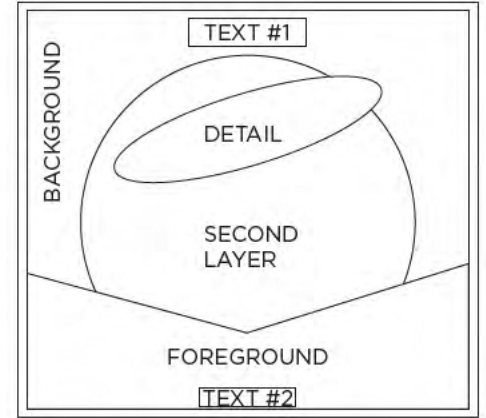
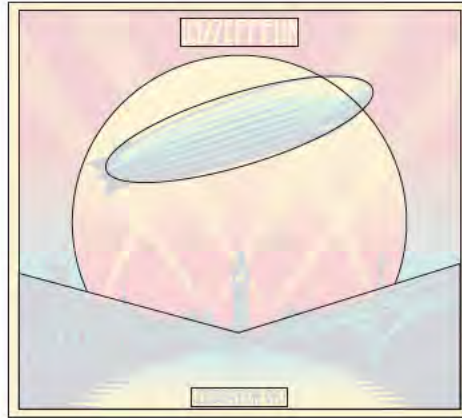

-
PARADIGM:
ELEMENTS CONNECTED
THROUGH ATTRIBUTES

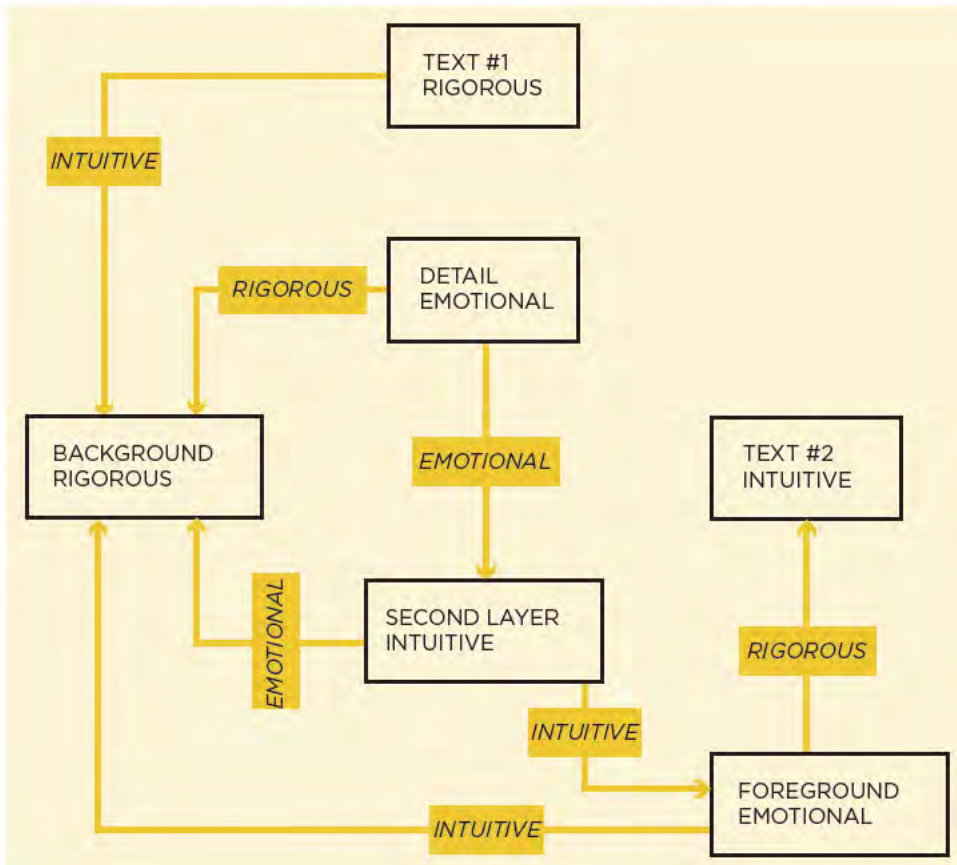

-
**ALICE
IN
WONDERLAND**



SECOND PROJECT

SECOND PHASE

SENARIO #1

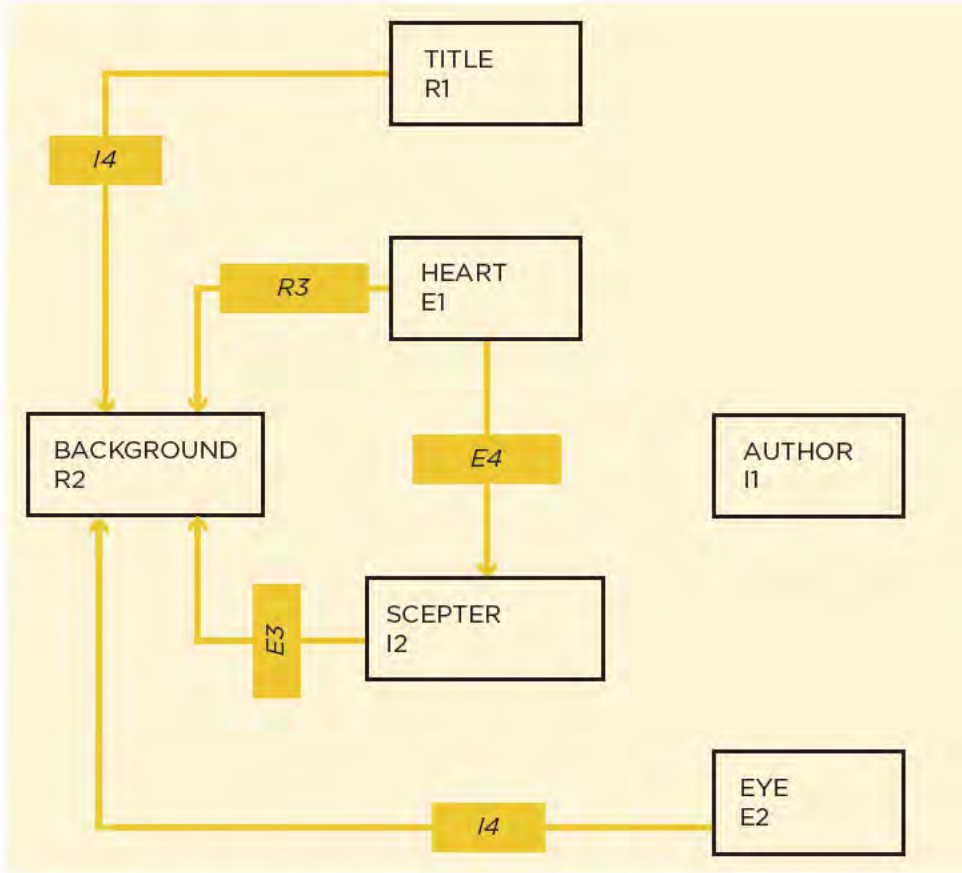

BACKGROUND



SCEPTER



EYE



SENARIO #2

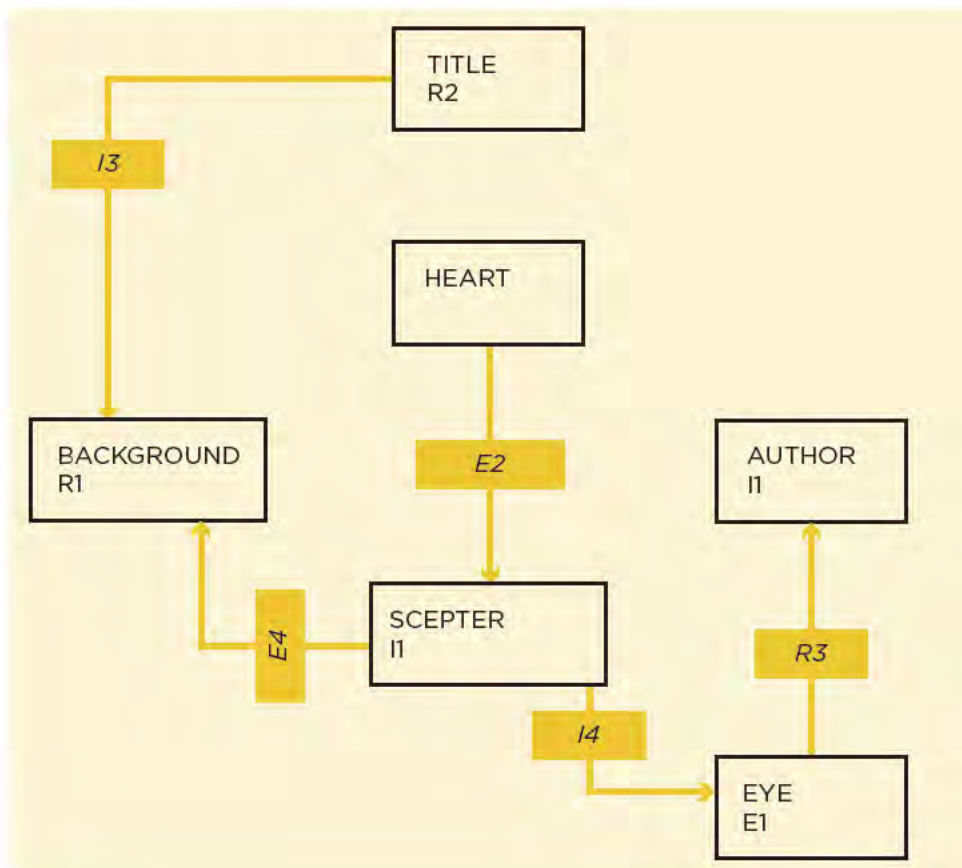

TITLE

**Alice in
Wonderland**

AUTHOR

**LEWIS
CARROLL**

HEART



SECOND PROJECT

SECOND PHASE

-
OUTPUT #1



-
OUTPUT #2

